

# AMS (Adjustable Concealed Monitor Switch) Pin & Barrel Hinge Electric Prep

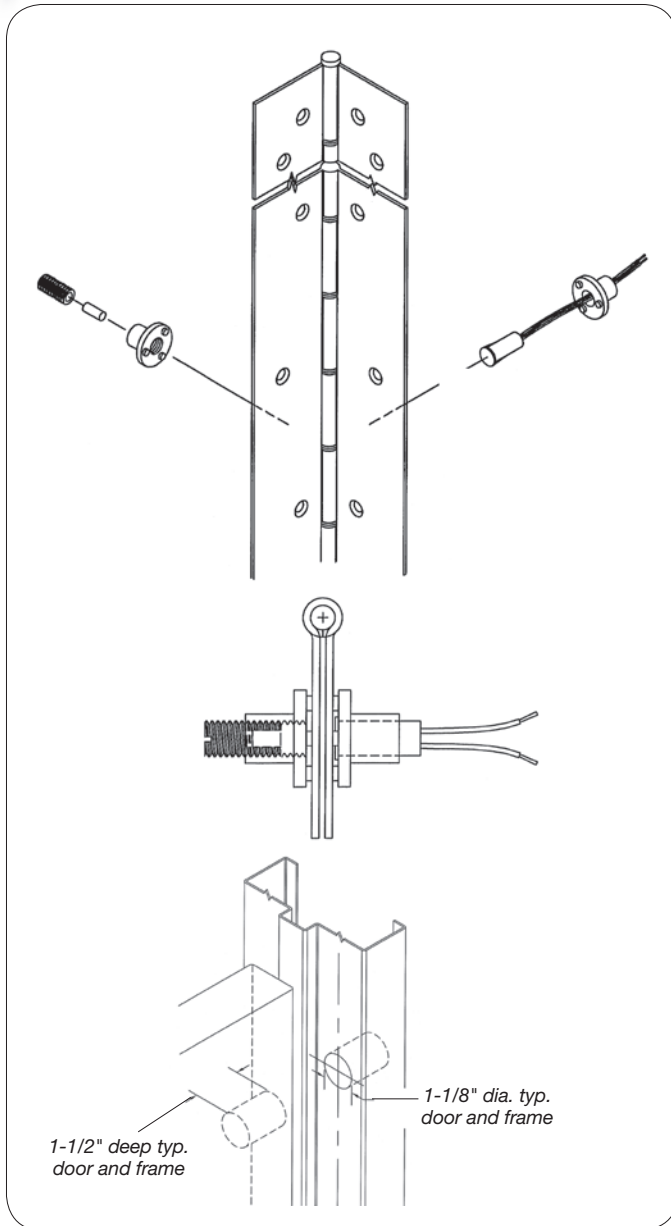

**PREP:** SELECT pin & barrel continuous hinges can be prepared for the adjustable concealed monitor switch. Rigid welded assembly gives you the ability to adjust the AMS to work with all applications.

**LOCATION:** Standard locations from top of hinge to centerline of AMS are as follows:

- 79" hinge = 35-3/8"
- 83" hinge = 37-9/16"
- 85" hinge = 38-1/2"
- 95" hinge = 43-1/2"

For custom locations, specify centerline dimension from top of hinge. Hinge is installed flush with the top of the door.

Refer to the templates in the Concealed Pin & Barrel Hinge section. These templates are also available online at [www.select-hinges.com/app](http://www.select-hinges.com/app).

**HANDING:** Specify the handing of each door requiring the AMS.

**ORDER:** Use suffix "AMS," plus the location and handing.

Example: SL300 83" SS, AMS 35-3/8" from top of hinge to centerline, LH.

**AVAILABILITY:** Available on pin & barrel hinge models SL200, SL300, SL305, SL315 and SL3500. NOT AVAILABLE on powder coat finishes.

**LEAD TIME:** Contact your SELECT representative.

**WARRANTY:** 5 years on electrical components.

**IMPORTANT:** SELECT Products Limited does not recommend preparing door and frame for AMS before receipt of hinge. If door and frame must be prepared before receipt of hinge, contact factory for special template.

AMS Prep